

THIS DRAWING IS UNPUBLISHED. RELEASED FOR PUBLICATION  
 © COPYRIGHT BY TYCO ELECTRONICS CORPORATION. ALL RIGHTS RESERVED.

LOC		DIST		REVISIONS			
P	LTR	DESCRIPTION		DATE	DWN	APVD	
	S	REV PER ECN 0G3B-0383-03		21AUG03	SC	JE	

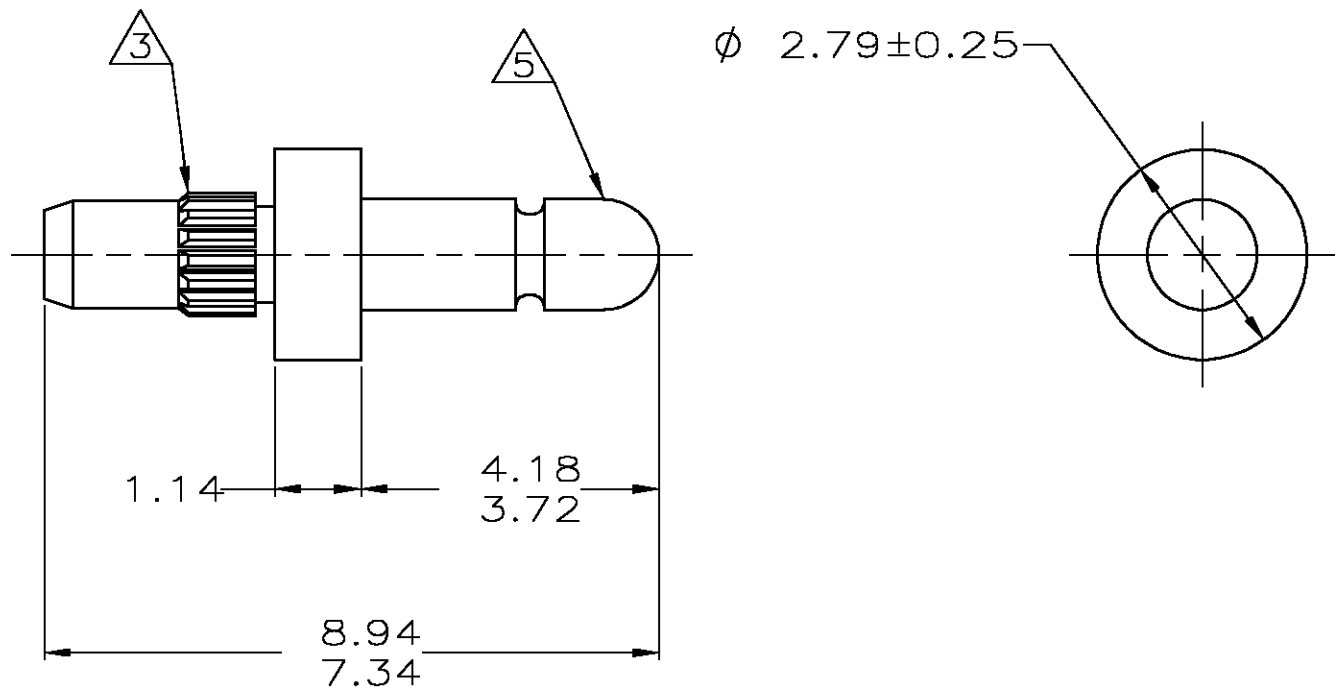

- ① 0.00381 MIN BRIGHT TIN-LEAD PLATING ALL OVER.
- ② 0.00076 MIN GOLD PLATING ALL OVER.
- ③ REED STRAIGHT TOOTH KNURL CS 80-80 T.P.I., 125 TEETH, 70° INCLUDED ANGLE. FITS 1.50 - 1.57 DIAMETER HOLE IN A 1.59 PRINTED CIRCUIT BOARD.
- 4. PARTS TO COMPLY WITH AMP SOLDERABILITY SPECIFICATION 109-11-3.
- ⑤ MATES WITH AMP PARTS 60354 AND 60598.
- ⑥ 0.00381 MIN BRIGHT TIN PLATING ALL OVER.

MM	IN
8.94	.352
7.34	.289
4.18	.165
3.72	.146
2.79	.110
1.59	.063
1.57	.062
1.50	.059
1.47	.058
1.14	.045
0.25	.010
0.13	.005
0.00381	.000150
0.00076	.000030
MM	IN

CONVERSION TABLE

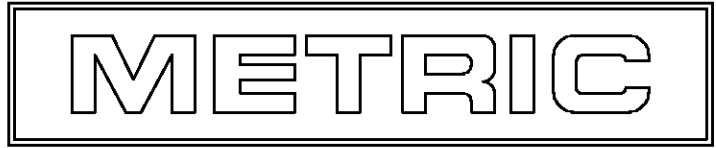

⑥	3-60599-1
②	60599-3
①	60599-1
FINISH	PART NUMBER

THIS DRAWING IS A CONTROLLED DOCUMENT.		DWN S. CARPENTER 21AUG2003	Tyco Electronics Corporation Harrisburg, PA 17105	
DIMENSIONS: MM		CHK J. ELLIS 21AUG2003	NAME PIN, .058 DIAMETER, BRASS, KNURLED, P.C. CONTACT	
TOLERANCES UNLESS OTHERWISE SPECIFIED:		APVD J. ELLIS 21AUG2003	PRODUCT SPEC 108-1025	
0 PLC ± 1 PLC ± 2 PLC ± 0.13 3 PLC ± 4 PLC ± ANGLES ±		APPLICATION SPEC 114-1008	RESTRICTED TO -	
MATERIAL BRASS	FINISH SEE TABLE	WEIGHT	SIZE A3	CAGE CODE 00779
CUSTOMER DRAWING			DRAWING NO C-60599	REV S
			SCALE 10:1	SHEET 1 OF 1